

Thank you for purchasing the JUXTA Signal Conditioner.
Please read through this manual before use for correct handling.

Yokogawa Electric Corporation
Network Solutions Business Division
2-9-32, Naka-cho Musashino-shi, Tokyo 180-8750 Japan
Phone: +81-422-52-7179 Facsimile: +81-422-52-6619

CAUTIONARY NOTES FOR SAFE USE OF THE PRODUCT

This User's Manual should be carefully read before installing and operating the product. Please keep this User's Manual for future reference. The following symbol is used on the product and in this manual to ensure safe usage.



This symbol is displayed on the product when it is necessary to refer to the User's Manual for information on personal and instrument safety. This symbol is displayed in the User's Manual to indicate precautions to avoid danger to the operator, such as an electric shock.

The following symbols are used only in this manual.



NOTE

Draws attention to essential information for understanding the operations and/or functions of the product.

CHECKING PRODUCT SPECIFICATIONS AND PACKAGE

(1) Checking the Model and Product Specifications

Check that the model and specifications indicated on the nameplate attached to the main unit are as ordered.

(2) Packaged Items

Check that the package contains the following items:

- FS1A or FS1V: 1
- Mounting block: 2
- Tag number label and Range label: 1 each
- Mounting screw (M4 x 0.7): 2
- User's Manual (this manual : IM 77J08S01-01E)

GENERAL

The FS1A/FS1V is a compact, front terminal connection type potentiometer converter that receives the resistance change signal from potentiometer attached to the control valve, and converts it into isolated DC current or DC voltage signals.

- Input range setting, burnout setting, zero/span adjustment, and I/O monitoring can be made using the optional Parameter Setting Tool (VJ77) or Handy Terminal (JHT200).

MODEL AND SUFFIX CODES

Model	Suffix codes			Description	
FS1A	-□	□	*C	Potentiometer Converter (Free Range Type)	
FS1V	/□□				
Input	-1			Total resistance range: 100 Ω to 2k Ω	
	-0			(Custom order) Total resistance range: more than 2k Ω and 30k Ω or less	
Output	A			4 to 20 mA DC	FS1A
	B			2 to 10 mA DC	
	C			1 to 5 mA DC	
	D			0 to 20 mA DC	
	E			0 to 16 mA DC	
	F			0 to 10 mA DC	
	G			0 to 1 mA DC	
	Z			(Custom order) DC current signal	
	1			0 to 10 mV DC	FS1V
	2			0 to 100 mV DC	
3			0 to 1 V DC		
4			0 to 10 V DC		
5			0 to 5 V DC		
6			1 to 5 V DC		
7			-10 to +10 V DC		
0			(Custom order) DC voltage signal		
Style code		*C		Style C	
Burnout		/BU		Up	
		/BD		Down	
		/BN		None	

1. MOUNTING METHOD

1.1 Installing/Uninstalling the Mounting Block

The mounting block is necessary for rack mounting or wall mounting.

Installing the mounting block

- Fit the mounting block into the grooves of the converter, and slide it in the direction of an arrow as shown below-left.

Uninstalling the mounting block

- Lift the stopper using a slotted screw-driver as shown below-right, and pull the mounting block to remove it.

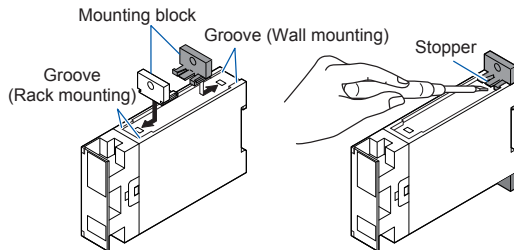

1.2 Rack Mounting

Take the FRK panel and install it on a mounting angle as shown below.

This method is suitable for high density mounting of the converters on a 19-inch rack panel.

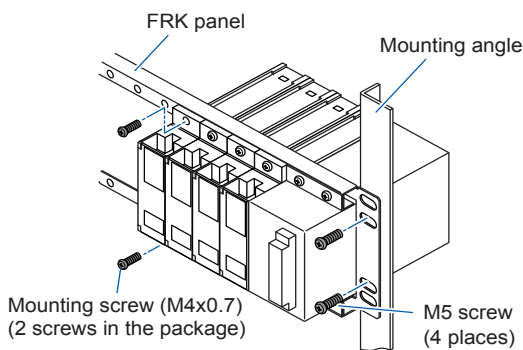

Mounting Dimensions Unit: mm

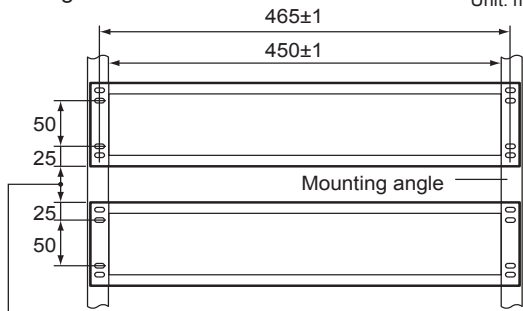

Supplied spacer(50) or Wiring space(30 to 60)

1.3 Wall Mounting

Mount the converter onto the FRK panel as shown below or mount it directly on the wall.

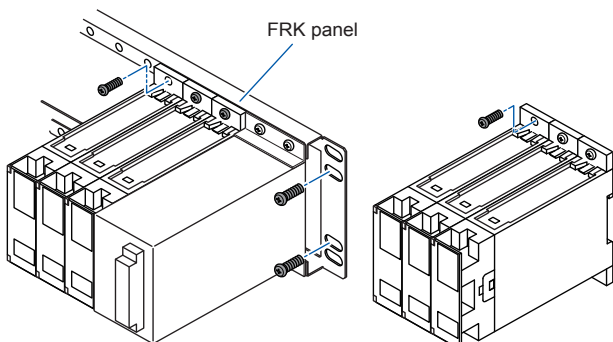

1.4 DIN Rail Mounting

Place the converter so that the DIN rail fits into the upper part of the DIN-rail groove at the rear of the converter, and push until it clicks. The converter is fixed by a slide lock (at the lower part on the rear side of the converter).

To remove the converter, pull down the slide lock using a slotted screw-driver.

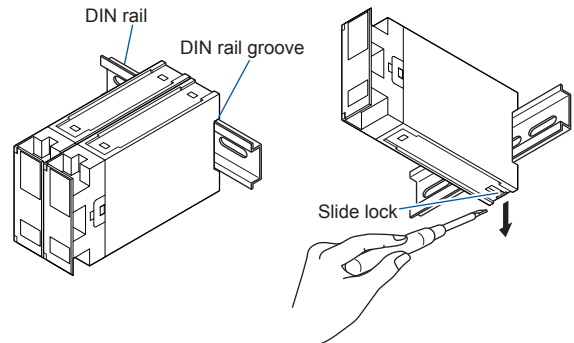

1.5 Mounting Dimensions

Unit: mm

Angle Mounting Dimensions

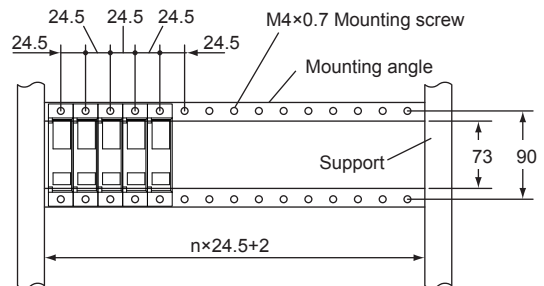

Wall Mounting Dimensions

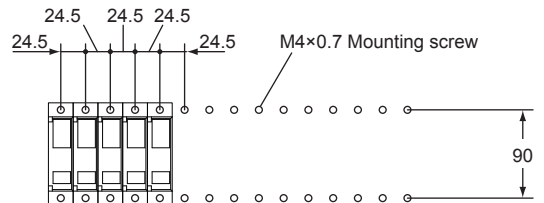

2. INSTALLATION LOCATION

- Avoid the following environments for installation locations: Areas with vibration, corrosive gases, dust, water, oil, solvents, direct sunlight, radiation, a strong electric field, and/or a strong magnetic field, altitude of more than 2000m above sea level.
- If there is any risk of a surge being induced into the power line and/or signal lines due to lightning or other factors, a dedicated lightning arrester should be used as protection for both this converter and a field-installed device.
- Operating temperature/humidity range: 0 to 50°C/5 to 90%RH (no condensation)

3. EXTERNAL WIRING



WARNING

Be sure to turn OFF the power supply before wiring to avoid the risk of electric shock. Use a tester or similar device to ensure that no power is being supplied to a cable to be connected.

M4 screw terminals are provided for the connection of external signals. Attach a crimp-on lug to each wire for connection to the terminals.

- Recommended cables: A nominal cross-sectional area of 0.5 mm² or thicker for signal cables, and that of 1.25 mm² or thicker for power cables.

Wiring Diagram

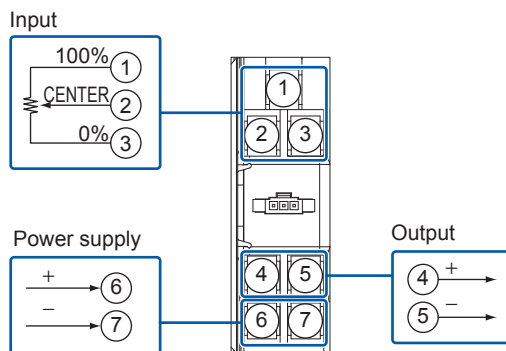

NOTE

- The power line and input/output signal lines should be installed away from noise-generating sources. Otherwise accuracy cannot be guaranteed.
- Adhere strictly to the specifications to avoid overheating or damage. Before turning on the power, ensure the following:
 - Power supply voltage and input signal value applied to the product should meet the required specifications.
 - The external wiring to the terminals are as specifications.
- Do not operate the product in the presence of flammable or explosive gases or vapors.
- This product is sensitive to static electricity; exercise care in handling. Before you operate the product, touch a nearby metal part to discharge static electricity.

Power Supply and Isolation

Power supply voltage: 24 V DC \pm 10% (percentage ripple: less than 5% p-p)

Current consumption: FS1A 65 mA, FS1V 50 mA

Insulation resistance: 100 M Ω at 500 V DC between input and output, output and power supply, and input and power supply.

Withstand voltage: 1500 V AC/min. between input and (output and power supply)
500 V AC/min. between output and power supply

4. SETTING PARAMETERS

The parameters are set as you specified in your order. Refer to the following to change the default settings.

Set the parameters using a PC (VJ77 Parameter Setting Tool) or the Handy Terminal. Refer to "5. List of Parameters" in this manual and the User's Manual for VJ77 PC-based Parameters Setting Tool (IM 77J01J77-01E) or the User's Manual for JHT200 Handy Terminal (IM JF81-02E). Parameters are shown in brackets "[]".

Connection of Setting Tools

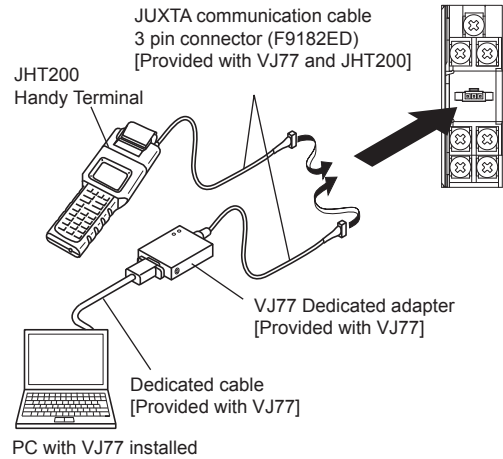

*Be sure to use the VJ77 of version R1.05 or later.

Setting Total Resistance

Set the total resistance in [B08: RESIST].

Setting range: 100 to 2000 Ω

Setting Input Range

Set the zero percent value of input range in [B10: ZERO], and the span of input range in [B11 : SPAN].

Setting range: 80 to 2000 Ω (more than 50% of the total resistance)

Setting Burnout Action

Set the burnout operation in [B12: BURN OUT].

Set "OFF", "UP", or "DOWN."



NOTE

Input adjustment should be applied when the input wiring, the setting of input range, or burnout operation has been changed.

5. LIST OF PARAMETERS

Parameter	Display	Items
A	DISPLAY	Display
A01	INPUT	Input value
A02	OUTPUT	Output value
A03	STATUS	Status (*1)
A04	REV NO	Revision number
B	SET	Setting
B01	TAG NO.1	Tag number 1
B02	TAG NO.2	Tag number 2
B03	COMMENT1	Comment 1
B04	COMMENT2	Comment 2
B08	RESIST	Total resistance
B10	ZERO	Zero (0% of input range)
B11	SPAN	Span (Input span)
B12	BURN OUT	Burnout
C	ADJUST	Adjustment
C01	OUT 0%	Output 0% adjustment
C02	OUT 100%	Output 100% adjustment
C06	ZERO ADJ	Input zero adjustment
C07	SPAN ADJ	Input span adjustment

*1: This "STATUS" is for the customer's engineer to check the history.

6. MAINTENANCE

The product starts running immediately when the power is turned on; however, it needs 10 to 15 minutes of warm-up before it meets the specified performance.

6.1 Calibration Apparatus

- 6-dial decade resistance boxes x 2 units (Yokogawa Meters & Instruments 279301 or equivalent)
- A digital multimeter, DMM (Yokogawa 7561 or equivalent)
- A precision resistor of $250\ \Omega \pm 0.01\%$, 1W
- A setting tool for adjustment (Refer to "4. Setting Parameters" in this manual)

6.2 Calibration Procedure

1. Connect the instruments as shown below.

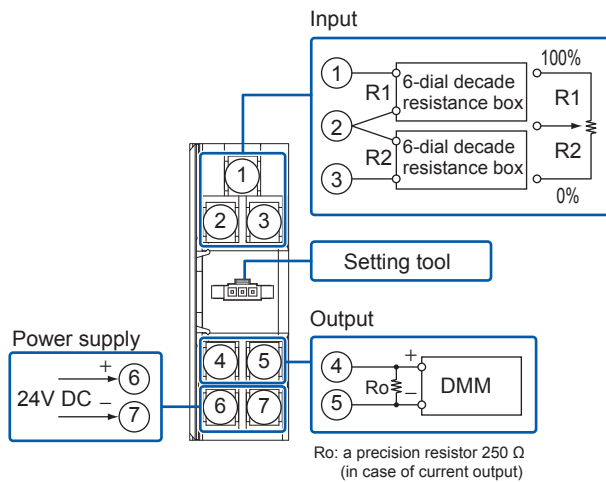

- 2 Keeping total resistance constant, change each value of R1 and R2 to apply the resistance equivalent to 0, 25, 50, 75, and 100% of the input range to the converter.
 3. Verify that the corresponding output voltages are 0, 25, 50, 75, and 100% respectively and within the specified accuracy rating. (Ro is used for current output.)
- Use the setting tool (VJ77 Parameter Setting Tool or JHT200 Handy Terminal) to adjust the input/output signals.

Input Adjustment Procedure

- (1) Set the total resistance of the potentiometer being combined, to the parameter **[B08: RESIST]**.
- (2) From the potentiometer, input the value equivalent to 0% value of the input range to the converter.
- (3) Read the parameter **[C06: ZERO ADJ]** and check the input value.
- (4) Fix the value, where **[C06: ZERO ADJ]** is displayed.
 - a. When adjusting by the JHT200, press **<ENTER>** twice.
 - b. When adjusting by the VJ77, click the **[WRITE]** button.
- (5) Input the value equivalent to 100% value of the input range to the converter from the potentiometer on site.
- (6) Read the parameter **[C07: SPAN ADJ]** and check the input value.
- (7) Fix the value, where **[C07: SPAN ADJ]** is displayed.
 - a. When adjusting by the JHT200, press **<ENTER>** twice.
 - b. When adjusting by the VJ77, click the **[WRITE]** button.



NOTE

- *The set value of the input range is automatically updated after the input adjustment. The adjustment value of **[C06: ZERO ADJ]** is overwritten in **[B10: ZERO]**, and that of **[C07: SPAN ADJ]** is overwritten in **[B11: SPAN]**, respectively.*
- *For the input adjustment, do not use the calibration apparatus but the potentiometer actually connected to this converter. The adjustment using the calibration apparatus causes the measurement error.*

Output Adjustment Procedure

When adjusting 0% value of output:

- (1) Set the adjustment value 0% in the parameter **[C01: OUT 0%]**.
 - The value equivalent to 0% of the output range will be output, irrespective of the input.
- (2) Check the output value via digital multimeter, and adjust it in the parameter **[C01: OUT 0%]**.
 - If the indicating value of DMM deviates to the (+) side, set (-) value equivalent to the deviation; if it deviates to the (-) side, set (+) value equivalent to the deviation for adjusting the output value to 0%.

*: The 100% value of output can be adjusted by the same operation as the above in **[C02: OUT100%]**

For adjustment using a setting tool, refer to the User's Manual for each setting tool and "5. List of Parameters" in this manual.

Use the VJ77 of version R1.05 or later.

User's Manual for the VJ77 [Document No.: IM 77J01J77-01E]

User's Manual for the JHT200 [Document No.: IM JF81-02E]